

CERTIFICATION



HACCP International



ISO9001

ICE MATE

by  **HOSHIZAKI**

SRM-450AB-S-B-501SA

ICE MAKER

DICE

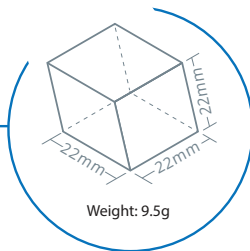

ICEMATE is committed to bringing high-efficiency / energy-saving, and high quality ice-making product to people who have dreams and desire to create their own business with the best scientific technology and manufacturing technology.

KEY FEATURES

SAFETY AND HYGIENE ASSURED ICE MACHINE

AUTO-CLEANING



Timely maintenance of water system can extend life of equipment.

PURE ICE



Overflow self-cleaning function, ensuring ice hygiene

IoT



Slow melt Dilution



Slow Dilution
Slower melting speed due to -7°C of inside temp of ice cube

Powerful Ice Making



Energy & Water Saving, Quiet Operation



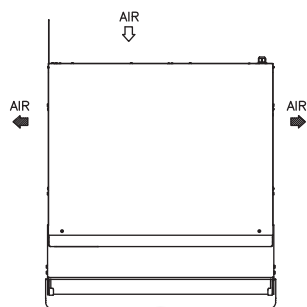

BIN TOP VIEW

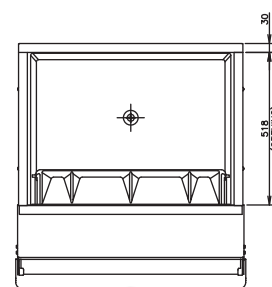

RIGHT SIDE

BACK SIDE

FRONT SIDE

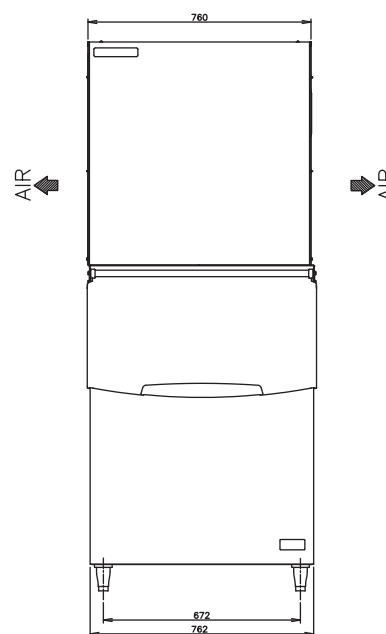
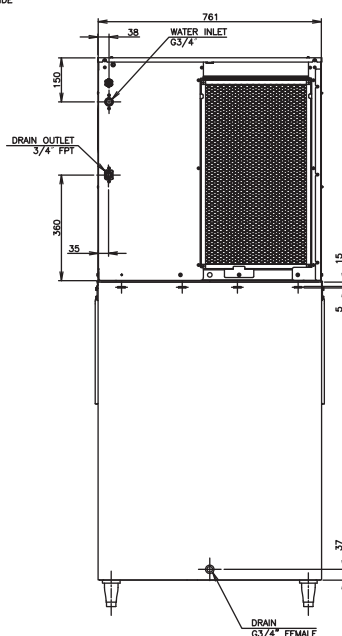
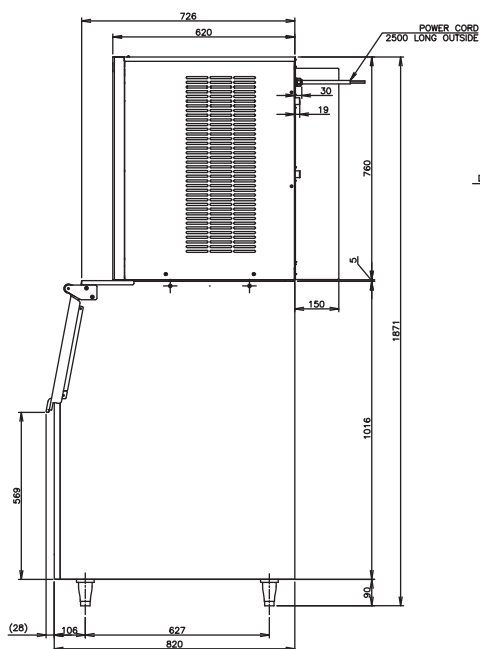

SPECIFICATIONS

Ice Dimensions (W x D x H)	22 x 22 x 22 mm
Outside Dimensions (W x D x H)	762 x 820 x 1871 (~1901) mm
Package Dimensions (W x D x H)	Ice Maker: Pallet+Carton: 865 x 720 x 945mm Storage Bin: 866 x 924 x 1138mm
Weight (Net / Gross)	Ice Maker: 95kg / 105kg Storage Bin: 47kg / 57kg
Amperage / Starting Amperage	10.81A/45.7A
Electrical Consumption	(AT32°C / WT21°C) 2094.5W
Refrigerant Charge	R404A/900g
Ice Storage Capacity	Maximum 217 kg
Ice Production per 24H	(AT10°C / WT10°C) Approx. 450 kg (AT21°C / WT15°C) Approx. 370 kg (AT32°C / WT21°C) Approx. 283 kg

Water Consumption per 24H	(AT32°C/WT21°C) 0.32m ³ (1.1 L / kg Ice)
Ice Production Freeze Cycle Time	(AT21°C/WT15°C) 15.8 min
Ice Production per Cycle	(AT21°C/WT15°C) Approx. 4.19kg / 440pcs

OPERATING CONDITIONS

Voltage Range	198 - 242 V
Ambient Temperature	5 - 38°C
Water Supply	5 - 32°C
Water Supply Pressure	0.07 - 0.55 Mpa (0.7 - 5.5 bar)
Supply Voltage	1/220 - 240V / 50Hz



HOSHIZAKI

HOSHIZAKI MALAYSIA SDN. BHD.

No. 12, Jalan Penyajak U1/45B. Hicom-Glenmarie Industrial Park, 40150 Shah Alam, Selangor
TEL (+60) 3 5569 8023 | <https://hoshizaki.com.my/>